



General Industry  
Flexachem support



## Summary

- Privately owned Cork based company founded in 1982
- The company portfolio delivers expertise for our customers across all business sectors
- Product focus of **Safety** through **Reliability** of performance – Giving our customers improved Uptime
- Focussed portfolio support via dedicated teams in Process Equipment, Valves, Pumps & Mechanical Seals

- Chemical
- Pharmaceutical
- Biotechnology
- General Process Industries
- Refinery plants
- Energy generation
- Paint
- Cosmetics
- Food and Beverage
- Meat Processing
- Water & Waste Water treatment
- Steam & Utility Applications
- Contractors & Process Skid Builders







Partnership approach  
with our clients to  
deliver engineered  
solutions to meet  
your application &  
performance needs –  
from component to  
project turnkey



## General summary

### Primary offerings

- Mixing Technology
- Full range of Pumps & Fluid transfer
- Full range of Valves & Flow control
  - WWTP support
  - Corrosion Resistant / Low friction pipework
  - Heat transfer
  - Pressure relief & Regulation
  - Production skids
  - Tank Cleaning

General  
Industry,  
Paint,  
Mining

---

Bauxite processing

---

Adhesive Production

---

Powder addition & mixing

---

Mine water recovery & Extraction chemicals

---

Tank agitators, pipeline mixing

---

Chemical dosing

---

Fluid transfer

---

Fluid and Gas control

---

Meat waste macerating, blood collection,  
waste transfer

# Energy Generation & Refineries

---

Pressure relief valves

---

Tank venting & Emissions control

---

Cooling Towers & Heat transfer

---

Full range of water, oil and fractionated liquid transfer

---

Mechanical Seals

---

Full array of valve control

---

Water treatment solutions

# Cosmetics & Healthcare industries

---

Production skids, Agitators and Homogenisers

---

Product & Powder blending

---

Clean in place skids

---

Tank cleaning

---

Transfer pumps

---

Valve control

---

Tank venting & emission control

---

Product recovery

---

SLES Skids



# Semi Conductor industries

---

Chemical transfer pumps

---

Chemical make up tanks

---

Air & Gas regulation

---

Tank breathing

---

Vapour control

---

Liquid & Gas control

---

Cooling Towers

---

Heat transfer

---

Purified Water systems & Valves

---



Tank Agitators – Centrally or Side mounted

---

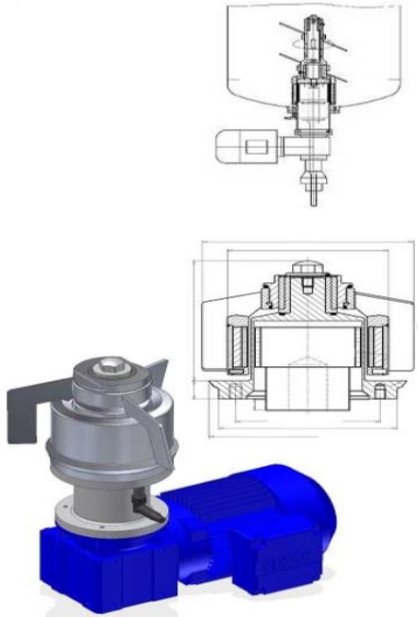

Magnetic drive agitators



Side entry agitators



Top entry agitators

# Tank Agitators – Top, Side or Bottom entry

From small vessel to larger silo, we cover all tank mixing applications

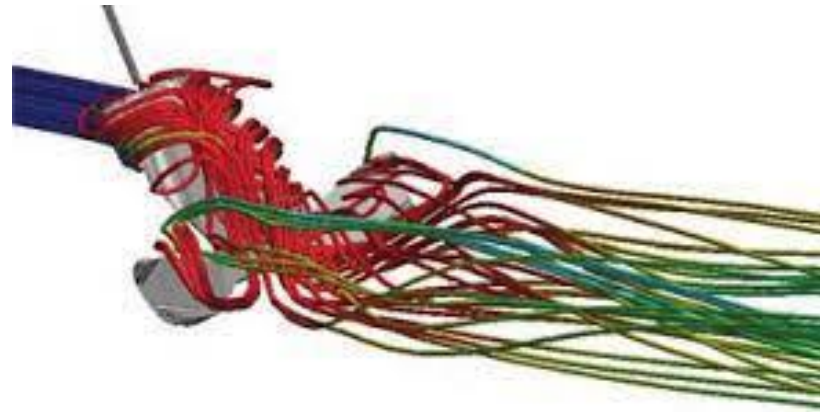

# Pipeline Static mixers

---



**FLOWSERVE**

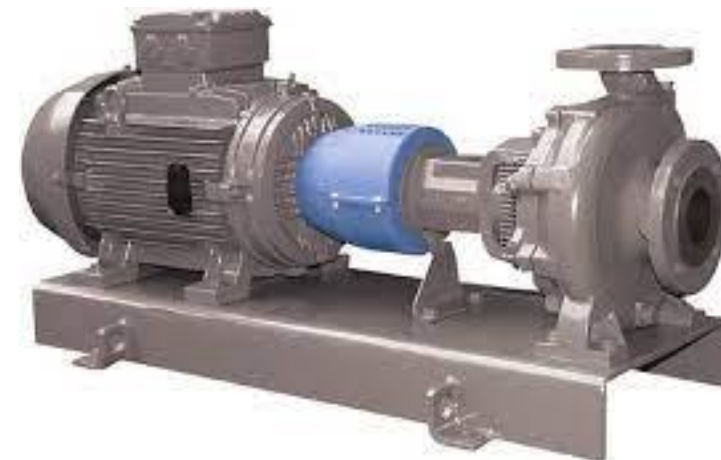

Centrifugal pumps

---







## Vacuum + Centrifugal pumps

- Durco Mark3 Process pumps
- Innomag Magnetic drive Sealless pumps
- SIHI Vacuum pumps
- Seal pots
- Commissioning & Alignment



Progressive Cavity

Rotary Lobe



Macerator



# NETZSCH

## Transfer pumps + Macerators



Corrosion resistant  
and low friction  
pipework



Filters + Strainers



Tank Level Gauges



Sight glasses



Expansion Bellows

# Pipeline & Tank components



# FLOWSERVE®

 **PBM**  
VALVE SOLUTIONS



# Product Valves





Flame Arrester



Venting



Bursting discs



Vapour control



Submersible pumps



Diffusers



Submersible aerators

# Aeration systems

# Product Heat Exchangers



**Kelvion**



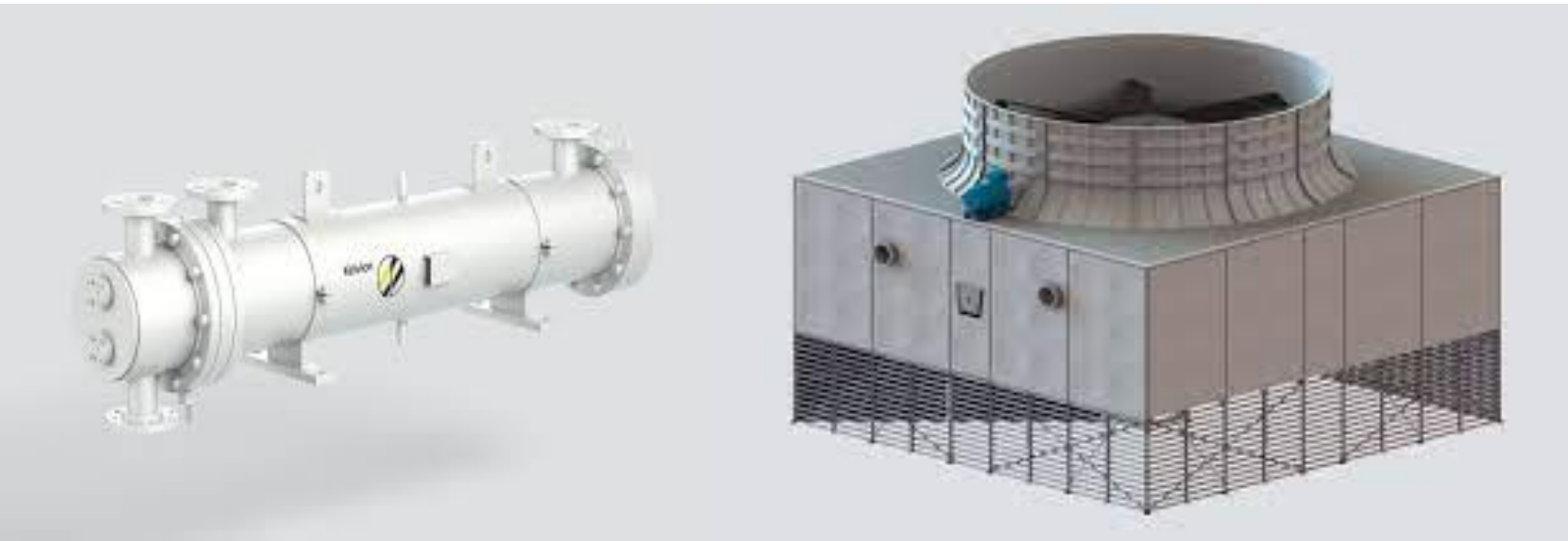

Shell & Tube

Cooling Towers



Plate + Frame

**Kelvion**



# Production solutions



Sample skids with high shear

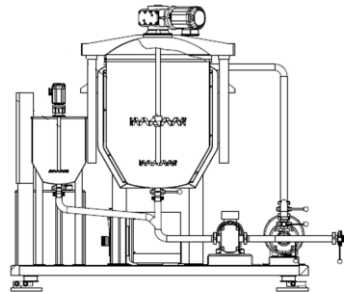

# Product Blending – Liquid and powder addition, homogenisation..etc

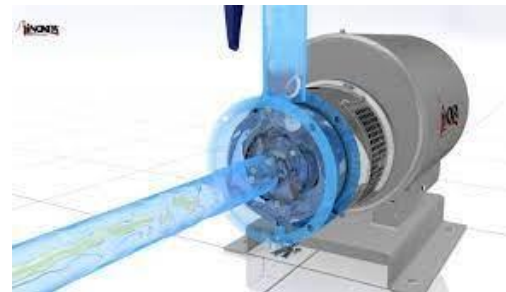



# CIP Skids – Mobile, semi + fully automated



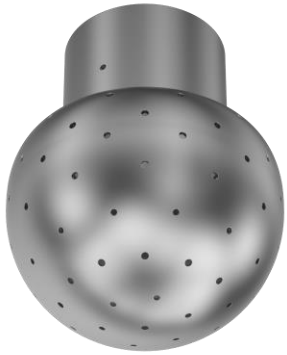

Class 1 –  
Static spray ball  
Range up to 5.2 metres



Class 2  
Rotating spray ball  
Range up to 2.6 metres



Class 3  
Rotating spray ball  
Range up to 3.0 metres



Class 4  
Rotating spray ball  
Range up to 9.5 metres



Class 5  
Rotating spray ball  
Range up to 24.0 metres

# Tank Cleaning



# Water Treatment

---

Tank agitators, static mixers, valves, pumps, submersible pumps, submersible agitators, surface & immersed aeration + diffusers

# Technical Comment

---

Full data sheets provided in support of selections offered

ATEX discussions will have a bearing on solutions offered

Lead times options will also be tabled

Site commissioning and sign off protocol to be agreed per product type in advance of purchase

Service engineers subject to our partners rate of site costs

# Lead times

---

- Longer lead items are typically agitators, tanks, aeration systems, some pumps
- Most other items fall into the 6-16 weeks bracket for delivery once specifications are known & confirmed with the factory
- Lead times are dependent on specifications agreed for the duties, factory loading, materials availability, payment stages and client approval for any drawings relevant for manufacture



# Finance

---

- Once overall budget is worked out this can be discussed
- A **value package** will also be available for multiple equipment spend
- Typically for CAPEX spend, stage payments will be involved
- Formal Purchase Order required for ISO audit purposes





# Project Support



Process

- Michael  
Bradley



Pumps

— Phil Soltan



Valves

– Brendan  
Merrigan



Seals

• Chris  
Sheeran

[Project Lead]

[Michael.Bradley@flexachem.com](mailto:Michael.Bradley@flexachem.com)

Mobile +353 86 0476178

[Phil.soltan@flexachem.com](mailto:Phil.soltan@flexachem.com)

Mobile +353 86 1853782

[Brendan.merrigan@flexachem.com](mailto:Brendan.merrigan@flexachem.com)

Mobile +353 87 2598124

[Chris.sheeran@flexachem.com](mailto:Chris.sheeran@flexachem.com)

Mobile +353 87 7559936